

BD355

CRAWLER DOZER



Salient Features :

- Turbocharged BEML BS6D170-1
- Power Shift Transmission
- Operator Comfort with Arm chair steering
- Pilot Operated Hydraulic System for work attachment
- Wet Multiple disc steering clutches and brakes
- Durable work attachment
- Segmented Sprockets
- Grooved-type Floating Seals
- Reduced vibration and noise level
- Hexagonal ROPS-FOPS Cabin for better visibility



BD355

Flywheel horsepower (net) : 310 kW (416HP) @
2000 rpm

Operating mass : 46550 kg
(with Semi-U dozer)

www.bemlindia.in

BD355

CRAWLER DOZER

Salient Features :

BEML BS6D170-1 Diesel Engine : Features a generous power to weight ratio for dynamic dozing performance.

Power Shift Transmission: Smooth and responsive gear shifts with single-lever for instant speed and directional changes.

Operator Comfort: Conveniently located armchair steering control for enhanced operator comfort with Hexagonal sound suppressive cabin.

Pilot Operated Hydraulic System : It offers effortless fine control blade through joystick.

Wet multiple disc steering clutches and brakes : Hydraulically inter linked steering clutch and brakes provide excellent maneuverability during gradual and pivot turns.

BEML unique engine speed control mechanism through braking (patent pending) gives better equipment control and helps reduce brake band wear and oil contamination.

Sturdy Construction: Track-roller frames are made of high tensile steel for maximum rigidity

Durable Work Attachment: High tensile steel blades of different configuration available for varying types of working conditions and applications. The attachment is sturdy in construction to withstand adverse ground conditions.

Segmental Sprockets : Bolt-on type segmented sprocket permits quick on site replacement. Special grooved type floating seals and unique dust seals provide extended undercarriage life.

Groove-type Floating Seals : These special seals are used in the idlers, track and carrier rollers to keep dirt out and lubricant in for extended undercarriage life, as well as reduced maintenance cost.

Reduced vibration and noise levels: Radiator, fuel tank, floor frame, Engine and cabin are mounted on anti-vibration rubber cushions to isolate vibration and reduce noise levels.



OPTIONAL FEATURES :

Electronic Governed engine is available
Electronic Transmission with Joystick control for Steering and Transmission is available.



ENGINE

Make	BEML
Model	BS6D170-1 / BS6D170EG (Optional)
Type	6 inline, Diesel, 4-stroke, water cooled, turbo-charged, direct injection, Mechanical Governed (Electronic Governed as Optional)
Flywheel power	310 kW (416 HP) @ 2000 rpm in accordance with IS:13116 / ISO: 9249
Maximum torque	1780 N-m (181.5 kg-m) @ 1400 rpm
No. of Cylinders	6, inline
Bore & Stroke	ø170 mm x 170 mm
Displacement	23.15 l (0.02315 m³)
Electrical	
Alternator	24V, 100 A / 140 A
Starter Motor	24V, 9 kW
Battery	2x12V, 200 Ah



TRANSMISSION

Torque Converter			
Type	3 element, single stage single phase		
Stall Ratio	2.6		
Transmission Type	4F/4R, Planetary power shift, transmission (Electronically Controlled as Optional)		
Final Drive Type	Spur and planetary gear, double reduction		
Lubrication	Splash type		
Total reduction	37.0		
Travel Speeds m/sec (km/h)	Range	Forward	Reverse
	1st	0-0.92 (0-3.30)	0-0.89 (0-3.20)
	2nd	0-1.42 (0-5.10)	0-1.39 (0-5.00)
	3rd	0-2.36 (0-8.50)	0-2.35 (0-8.47)
	4th	0-3.53 (0-12.7)	0-3.50 (0-12.6)



STEERING

Type	Wet, multiple disc steering clutches are hydraulically actuated and require no adjustment
Min. Turning Radius	3.7 m
Steering Control	Hydraulic through linkages (Joystick as optional)

STANDARD EQUIPMENT :

- Hydraulic Track Adjusters
- Air cleaner inner element lock
- Track roller guard (each side)
- Decelerator pedal
- 7 Roller track frame
- Lower guard (3 pieces)
- Fixed type draw bar
- Joystick for work attachment
- Adequate lighting system
- Front pull hook
- In-line radiator
- Tool kit
- Audio visual backup alarm
- Lighting System (including 4 front and 2 rear lights)
- Safety lock for blade lever
- Semi-U Blade
- Hex. ROPS- FOPS cabin

METERS & GAUGES

- Engine oil pressure
- Engine water temperature
- Torque converter oil temperature
- Engine tachometer
- Hour meter
- Voltmeter
- Transmission oil pressure
- Fuel level
- Engine oil temperature

WARNING INDICATORS

- Engine oil filter clog
- Battery Charging (indicator only)
- Engine oil pressure
- Torque converter oil temperature
- Engine coolant level
- Engine coolant temperature
- Engine oil temperature
- Dust Indicator (Mechanical on engine)
- Seat Belt Indicator
- Engine Auto shut off for low engine oil pressure and high water temperature abnormalities.

OPTIONAL ATTACHMENTS / SYSTEMS

- Straight Tilt Blade
- U-Blade
- Angle Blade
- Coal Blade
- Giant Ripper
- Pin puller equipment (for Giant ripper)
- Track shoe 710mm
- Track shoe 760mm
- AC with Heater & Defroster

- Pusher plate for straight tilt dozer
- Scoria Disposal
- Multi shank Ripper
- Rake Dozer
- Fast fill fuel system
- Warning system for operator's fatigue.
- Auto Lubrication system
- Automatic temperature control unit for AC
- Rear vision system
- Auto fire detection & suppression system



HYDRAULIC SYSTEM

Hydraulic pump		Pilot pump
Type	Gear pump	Gear pump
Capacity	419.3 ℓ / min.	24.00 ℓ pm
Relief pressure	13.73 MPa (140 kg/cm ²)	3.0 MPa
Hydraulic Cylinders		
Type	Double acting piston type	
Blade Lift	2 cylinders	
Bore x Stroke (mm)	∅ 160 mm x 1440 mm	
Blade Tilt	1 cylinder	
Bore x Stroke	∅250 mm x 180 mm	
For optional ripper attachment		
Ripper lift	2 Cylinders	
Bore x Stroke	∅ 225 mm x 600 mm	
Ripper tilt	2 Cylinders	
Bore x Stroke	∅ 225 mm x 500 mm	



FILTRATION

Engine	Replaceable cartridge type filter for lubrication as well as for fuel line.
Transmission	One magnetic oil strainer and one replaceable element pressure line filter
Steering & Brake	Magnetic oil strainer is common to transmission, steering & braking system. Separate replaceable element type pressure line filters are provided.
Hydraulic System	Magnetic plug & replaceable element type filter is provided. Pilot filter with cleanable element.



UNDER CARRIAGE

Suspension	Oscillation type equalizer bar
Track Frame	Box section High tensile strength steel construction
Track Roller	7 No. Each side
Carrier Rollers	2 No. Each side
Track Shoes	39 No. Each side
Track Pitch	2260 mm
Grouser Height	88 mm
Shoe Width	610mm (standard)
Ground Pressure	83.70 kPa (0.85 kg/cm ²) (Tractor)
Ground contact area	4.099 m ²



MASS (approximate)

Operating mass (Standard equipment with Semi-U dozer)	46550 kg
Shipping mass (Basic tractor with lubricants, Hydraulic system, cooling system and 10% of fuel tank capacity)	35000 kg



BRAKE

Type	Wet, contracting band,
Control	Foot operated steering brakes with hydraulic booster for light-touch actuation and long service life. Brakes and steering clutches are interconnected for easy steering.
Parking brake	Hand operated with mechanical linkage.



DIMENSIONS mm

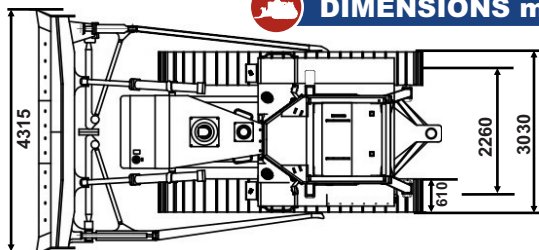

Ground Clearance : 570mm

Material and specifications are subject to change without notice, Illustrations may include optional equipment & accessories



DOZER ATTACHMENT

Dozer type	Straight tilt dozer	Angle dozer	Semi-U dozer	U dozer	Coal dozer
Overall length with dozer (mm)	7120	7215	7163	7600	7760
Blade length x height (mm)	4315 x 1875	5230 x 1350	4315 x 1955	4715 x 1875	5530 x 2125
Max. lift above ground (mm)	1545	1640	1545	1545	1565
Max. drop below ground (mm)	700	720	700	700	650
Max. tilt adjustment (mm)	1000	550	1000	1000	*
Additional ground pressure kPa (kg/cm ²)	20.6 (0.21)	19.6 (0.20)	20.6 (0.21)	23.54 (0.24)	19.62 (0.20)
Blade Capacity (m ³)	11.6	5.9	13.0	15.6	24.5
Mass in kgs					
Dozer Attachment	7830	7200	8590	8830	7660
Hydraulic Control Unit	880	870	880	880	680

*Tilt Cylinder for coal dozer is optional



COOLANT & LUBRICANTS CAPACITY (Refill)

System	Specific amount(ltr.)	Refill capacity(ltr.)
Cooling System	180	–
Fuel tank	760	–
Engine Lub oil	58	43
Transmission, bevel gear torque converter & steering	230	190
Final Drive (each side)	68	68
Hydraulic System	350	185



BD355 DRAWBAR PULL Vs TRAVEL SPEED

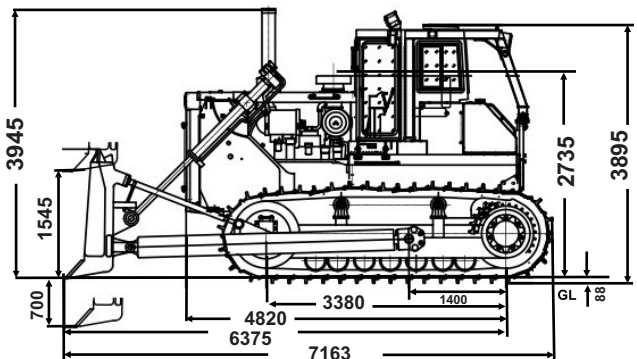
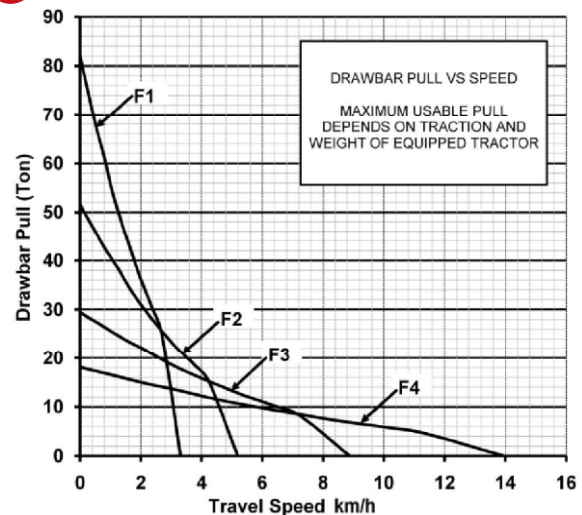

BD355

CRAWLER DOZER

TECHNICAL SPECIFICATIONS

बी ई एम एल लिमिटेड

BEML LIMITED

Schedule 'A' Company under Ministry of Defence, Govt. of India

Business Network

Corporate Office

BEML Soudha, 23/1, 4th Main,
S.R. Nagar, Bangalore – 560 027

T +91 80 22963240, 22963250

F +91 80 22963278/516/280/164

E-mail: office@cpd.beml.co.in
corpcomm@beml.co.in

International Business Division

Flat No. E,F,G, H, 'Vandana' 11th Floor,
11, Tolstoy Marg, Connaught Place
New Delhi – 110 001

T + 91 11 23316500
F + 91 11 23325085

E-mail: mx@beml.co.in

Marketing Division

5th Floor, Unity Building,
J.C. Road, Bangalore – 560 002

T + 91 80 22963501/02/07/510/540

F + 91 80 22963541

E-mail: m@beml.co.in
mmd@beml.co.in

REGIONAL OFFICES

Bangalore

3rd Floor, Unity Building, J. C. Road,
Bangalore - 560 002
Karnataka

T +91 80 2296 3524
T +91 97413 51588
E-mail: mg@beml.co.in

Bilaspur

1-A, Industrial Area, Sector-C, Sirgitti,
Bilaspur - 495 223.
Chhattisgarh

T + 91 7752 252745, 252598
F + 91 7752 252065
E-mail: mv@beml.co.in

Neyveli

F-4, Dr. Rajendraprasad Road,
Block-27, Neyveli, - 607 803
Tamil Nadu

T/F + 91 4142 268517
T + 91 4142 265517 / 229392
E-mail: ma@beml.co.in

Dhanbad

Mouza - Kangalo, Amaghata,
Govindpur, KG Ashram Post, Dhanbad
Jharkhand – 828 109

T + 91 94711 92023
E-mail: mf@beml.co.in

Hyderabad

3-6-114, Street No.18, Himayat Nagar,
Hyderabad - 500 029
Telangana

T + 91 40 2322 7032 / 94907 93117
F + 91 40 23221794
E-mail: hyderabad@rm.beml.co.in

Kolkata

35/1A, Taratala Road,
Kolkata - 700 088.
West Bengal

T + 91 33 2401 5286 / 87 / 98 / 99
F + 91 33 2401 5288
E-mail: kolkata@rm.beml.co.in

Mumbai

32A, Bazar Road,
Near Jain Mandir, Bandra (West), Mumbai,
Maharashtra - 400 050

T + 91 22 26431875 / 26435875
F + 91 22 26423928
E-mail: mumbai@rm.beml.co.in

Nagpur

No 33, Cement Road,
Shivaji Nagar,
Nagpur - 440 010, Maharashtra.

T + 91 712 2248435 / 2248343
F + 91 712 2249997
E-mail: nagpur@rm.beml.co.in

New Delhi

Flat E,F,G,H, 'Vandana', 11th Floor,
11, Tolstoy Marg, Connaught Place,
New Delhi - 110 001

T + 91 11 2344 3511 / 3528 / 2331 6500
F + 91 11 2332 5085
E-mail: mlm@rm.beml.co.in

Ranchi

206/D-1, Bhagirathi, (Behind NCC Campus)
Rameshwaram Colony, Bariatu Road,
Ranchi, Jharkhand - 834 009

T + 91 651 2540710 / 94311 08531
E-mail: ranchi@rm.beml.co.in

Sambalpur

BEML Complex, NH-6, Panchagachhia,
Baraipalli Post, Sambalpur 768 006
Odisha.

T + 91 663 2521604 / 2521389
E-mail: mb@beml.co.in

Singrauli

PB No. 5, Jhingurdha Colliery,
Singrauli - 486 889
Madhya Pradesh.

T + 91 7805 272668 / 272318
F + 91 7805 272282
E-mail: singrauli@rm.beml.co.in

ACTIVITY CENTRES

Bhopal

Ground Floor, Hall No.1, Chittod Complex, Zone-1,
Maharanapratap Nagar (MP Nagar), Bhopal - 462 011

T + 91 755 2550711 / 8989459753

Panjim

BEML Limited, 5/4, Victor Building, Fontanhas, Mala,
Panjim - 403 001, Goa

T +91 832 2225135 / 77986 87178
E-mail: goa@rm.beml.co.in

Itanagar

C/o. Tobom Riba, H-Sector, Papum
Itanagar – 791 113, Arunachal Pradesh

T + 91 94029 34205 / 88372 15852
E-mail: mcgi@beml.co.in

Kochi

No. 39/2122, Chittoor Road, Ernakulam South,
Kochi – 682 016

T + 91 484 2375138
E-mail: kochi@rm.beml.co.in

Maihar

Maihar, Madhya Pradesh

Mob: +91 79875 53768

Silapathar: Surya Vatika, Amritpur, Silapathar, Assam - 787 059 T +91 95311 29059

DISTRICT OFFICES

Ahmedabad

99/100, BEML HOUSE, 2nd Street,
Azad Society, Ambawadi,
Ahmedabad - 380 015, Gujarat

T + 91 79 26445523 / 94264 13620
F + 91 79 26423950
E-mail: ahmedabad@rm.beml.co.in

Asansol

3, Burnpur Road,
Asansol - 713 304
West Bengal

T + 91 341 2252480
F + 91 341 2250601
E-mail: asansol@rm.beml.co.in

Bacheli

Behind Central Stores of NMDC Ltd.,
Depot 5, Bacheli - 494 553.
Chhattisgarh

T/F + 91 7857 230005
E-mail: bacheli@rm.beml.co.in

Bhilai

Room no 22/C, BSP Expansion Building,
Near Ispat Bhavan, Bhilai 490 001, Chhattisgarh

T + 91 788 2223880
F + 91 788 2221652
E-mail: mnboffice@beml.co.in

Bhubaneswar

252/A, Lewis Road
Bhubaneswar - 751 014
Odisha

T + 91 674 2434427 / 99373 83950
E-mail: mbb@beml.co.in

Chandrapur

Mamidwar, Tiles Factory Compound
Ghugus Road, Padoli
Chandrapur - 442 406 Maharashtra

T + 91 7172 287230
F + 91 7172 287560
E-mail: mnc@beml.co.in

Chennai

Fiat No. 10, Supriya Estates,
No.3, Sterling Road, Nungambakkam,
Chennai - 600 034, Tamil Nadu,

T + 91 44 28220844
F + 91 44 28257319
E-mail: chennai@rm.beml.co.in

Guwahati

No.11, Ward 43, Hengrabari Road,
Ganesh Puri, Dispur,
Guwahati - 781 006 Assam

T + 91 361 2232966
F + 91 361 2232967
E-mail: guwahati@rm.beml.co.in

Hospet

No.1431, Manjunatha Complex,
Bhagat Singh Nagar, Opp. KSSIDC Indl. Estate,
Dam Road, Hospet - 583 203, Karnataka

T/F + 91 8394 230172
E-mail: hospet@rm.beml.co.in

Jammu

62C, Block D/C, Gandhi Nagar,
Jammu tawi - 180 004
Jammu and Kashmir

T + 91 191 2459 437
F + 91 191 2430 447
E-mail: mlj@beml.co.in

Kothagudem

Old Project Planning Department,
Near SCCL Corporate Office,
Kothagudem - 507 101, Telangana

T + 91 8744 245572
F + 91 8744 245530
E-mail: kothagudem@rm.beml.co.in

Leh

174-B, (Near Royal Enfield Showroom),
Housing Colony, Leh, Ladakh -194 101

T + 91 1982 258828 / 94198 71008
E-mail : ml@beml.co.in

Ramagundam

Near SCCL TTC, Jawahar Nagar,
Behind CISF Camp, Godavarikhani - 505 209.
Peddapalli Dist.,Telangana

T + 91 8728 248299 / 94408 58441
E-mail: mhr@beml.co.in

Udaipur

20-B, Uchhab Bhavan, Bedla Road,
Fatehpura, Udaipur - 313 001.
Rajasthan

T + 91 294 2452054
E-mail: mwu@beml.co.in

Visakhapatnam

No. 8-45-11, 4th Lane, Vidyanagar Chinna Waltair Colony
Visakhapatnam - 530 003, Andhra Pradesh

T/F +91 891 2754608 / 83320 54590
E-mail: vizag@rm.beml.co.in

www.bemlindia.in

Represented by:

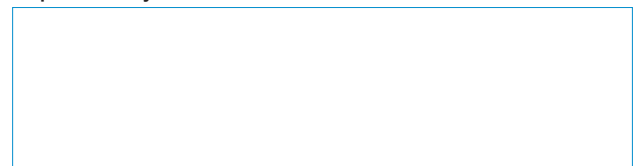

बी ई एम एल लिमिटेड

BEML LIMITED

Schedule 'A' Company under Ministry of Defence, Govt. of India

Crawler Dozers From BEML :

BD50

BD65-1

BD80

BD85

BD155

BD355

BD475

Form No. BD355/01/2020